



## MR 专业型可移动缸和面机

MR Professional — Spiral Mixers with Removable Bowl

---

产量：80, 120, 160, 200或240公斤  
Capacity 80, 120, 160, 200 and 240 kg



# MR 专业型可移动缸大产量和面机

每位面包师都知道，优质的面团是优质烘焙产品的基础，而优秀的和面机又是制作高品质面团的关键。

Sveba-Dahlen 针对烘焙处理的每一个环节设计制造高品质的设备，我们的和面机以坚固耐用闻名世界；提供各种不同的规格来适合所有规模的面包工厂和连锁店，我们引以为傲。

MR专业型高性能和面机，带移动缸，使用了专利缸体锁紧和旋转驱动技术。MR专业型和面机涵盖了产量从80至240公斤多种规格，满足大中型面包房生产需求。

## 特点及优势

专利缸体锁紧和旋转驱动技术是利用锥形轴将机身与和面缸连接成整体；当和面缸推到位后，锥形轴从缸体底部往上升，对准缸体中心点，把缸体定位于中心位置；液压控制锥体从缸体底部锁紧，确保缸体不会产生滑动和摩擦。锥形轴驱动缸体匀速转动，大大提升面团质量；此驱动装置噪音低，机械运动平稳流畅。

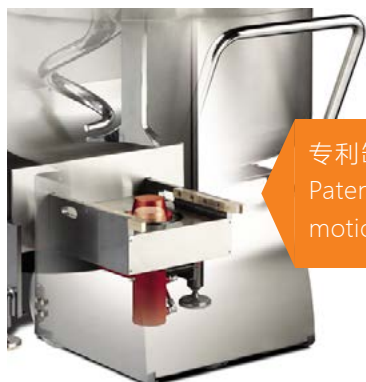

专利缸体锁紧和驱动技术  
Patented locking and motion system

缸体锁紧和驱动系统

*Bowl locking and motion system*



触控面板（选项）

*Touch screen (option)*

## 选项

- 附加缸，MRC
  - 固定刮刀
  - 红外线温度检测
  - PTC温度传感器
  - 馅料、面糊搅拌器
  - 搅拌工具快速更换
  - 快速更换的搅拌钩
  - 快速更换的搅拌器
  - 缸体带排水塞
  - 触摸屏
  - 变速驱动系统
  - 可拆卸刮刀
- 不锈钢外表
  - 更强劲的马达：
    - MR 80 P, 4.0/7.6 kW
    - MR 120 P, 4.0/7.6 kW
    - MR 160 P, 9.0/15.0 kW
    - MR 200 P, 9.0/15.0 kW
    - MR 240 P, 11.0/18.0 kW

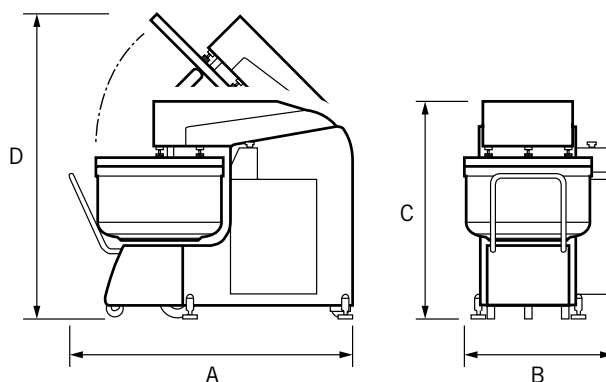

# MR Professional. High capacity Spiral Mixer with Removable Bowl

As any baker will tell you, a good mixer is vital to making high quality dough, and a good dough in turn is the basis for all high quality baking products.

Sveba-Dahlen takes pride in manufacturing high end baking equipment for every step of the baking process. Our range of Spiral mixers are world renowned for their sturdiness and durability, and we have models suitable for all types of bread and bakery products for every size of bakery.

MR Professional is a series of high performance spiral mixers with a removable bowl and a patented system for motion control and taper bowl locking. The MR mixer comes in versions with dough capacity ranging from 80 to 240 kilograms, making this model suitable for medium to large size bakeries.

## FEATURES AND BENEFITS

- A patented taper bowl locking and motion system utilizes a taper coupling to connect the machine and the trolley.
- The trolley is locked by means of a taper shaft that, as it ascends, centers the bowl and moves it into the working position.
- The hydraulically controlled cone engages under the bowl and maintains constant pressure during use, eliminating any possibility of slippage or wear.
- The taper shaft gives rotating motion to the bowl and guarantees a constant number of bowl revolutions thereby increasing the dough quality and machine performance.
- The motion system is noiseless and free of mechanical play.

## OPTIONS

- Extra bowl, MRC
- Fixed bowl scraper
- Infrared temperature measurement.
- PTC temperature probe
- Beater for pastry dough
- Quick change system for tools
- Spiral for the quick change system
- Beater for the quick change system
- Bowl with drain plug
- Touch screen
- Vario drive system
- Removable bowl scraper
- Stainless steel finish
- Stronger motors:  
MR 80 P, 4.0/7.6 kW  
MR 120 P, 4.0/7.6 kW  
MR 160 P, 9.0/15.0 kW  
MR 200 P, 9.0/15.0 kW  
MR 240 P, 11.0/18.0 kW

## 技术参数 TECHNICAL

型号 MODEL	面团产能 DOUGH CAPACITY	面粉产能 FLOUR CAPACITY	缸容量(升) BOWL VOLUME (L)	1速/2速功率 POWER OF SPIRAL 1 <sup>st</sup> /2 <sup>nd</sup> SPEED	缸体驱动功率 POWER OF BOWL	总功率 POWER SUPPLY	重量 WEIGHT
MR 80 P	80 kg	50 kg	154	3.0 kW/6.25 kW	1.1 kW	7.35 kW	1100 kg
MR 120 P	120 kg	75 kg	181	3.0 kW/6.25 kW	1.1 kW	7.35 kW	1150 kg
MR 160 P	160 kg	100 kg	270	7.5 kW/12.5 kW	1.1 kW	13.6 kW	1250 kg
MR 200 P	200 kg	125 kg	310	7.5 kW/12.5 kW	1.1 kW	13.6 kW	1390 kg
MR 240 P	240 kg	150 kg	380	9.0 kW/15.0 kW	1.1 kW	16.1 kW	1500 kg

## 尺寸 MEASUREMENTS

外观尺寸 (mm) DIMENSIONS (mm)			
A	B	C	D
1775	904	1470	1920
1815	939	1470	1920
2001	1027	1500	2051
2031	1060	1500	2058
2056	1105	1500	2136



## 瑞典制造 享誉世界 MADE IN SWEDEN. LOVED AROUND THE WORLD.

从街角的小型手工面包坊到大型工业面包企业及连锁店，无论您身处世界何地，当您走进面包店，都有可能发现Sveba-Dahlen的身影。我们秉承瑞典制造工艺，凭着对面包与烘焙的热爱，针对产品烘焙的各个阶段，致力于为不同规模的专业面包企业研发、制造和销售瑞典顶级烘焙设备。

From the small artisan bakery on the corner, to large industrial bakeries: Wherever in the world you walk in to a bakery, you are likely to find Sveba-Dahlen. With a heritage in Swedish engineering and a passion for bread and baking, we develop, manufacture and sell equipment for every stage of the baking process for professional bakeries of all sizes.

DeRui Food Equipment (Shenzhen) Co.,Ltd.

**德瑞食品设备（深圳）有限公司**  
深圳市南山区田厦国际中心  
(桃园路与南光路交汇处) A-2306  
邮编518000  
电话：+86 755 8657 1799  
传真：+86 755 8657 9896  
邮箱：info@dr-foodtech.com  
网址：www.dr-foodtech.com

**DR | FOODTECH**  
德 瑞 食 品 设 备